

Compax3M Installation Manual

Multi-axis devices

Paper version



C3Manager-Compax3M

Unterlagen / Software
user guides / tools

manuels / tools:

- ◆ Compax3 - DVD (english, deutsch, français)
- +
- ◆ Compax3M Installations-Handbuch deutsch
- ◆ Compax3M Installation Manual english
- ◆ Manuel technique Compax3M français

192-120148N3

October 2008

Release R08-0

Windows NT®, Windows 2000™, Windows XP™, Windows Vista are trademarks of Microsoft Corporation.

Nonwarranty clause

We checked the contents of this publication for compliance with the associated hard and software. We can, however, not exclude discrepancies and do therefore not accept any liability for the exact compliance. The information in this publication is regularly checked, necessary corrections will be part of the subsequent publications.

Production site:



Parker Hannifin GmbH & Co. KG
 Electromechanical Automation Europe [EME]
 Robert-Bosch-Strasse 22
 77656 Offenburg (Germany)
 Tel.: + 49 (0781) 509-0
 Fax: + 49 (0781) 509-98176
 Internet: **www.parker-automation.com** <http://www.parker-automation.com>
 E-mail: **sales.automation@parker.com** <mailto:sales.automation@parker.com>

Parker Hannifin GmbH & Co KG - Location: Bielefeld - Amtsgericht: Bielefeld HRA 14808
 Personally liable shareholder: Parker Hannifin Management GmbH - Amtsgericht: Bielefeld HRB 35489
 Geschäftsführung: Dr. Gerd Scheffel, Günter Schrank, Christian Stein, Kees Veraart, Hans Wolfs - Chairman of the board: Hansgeorg Greuner

Headquarters:

Great Britain:

Parker Hannifin plc
 Electromechanical Automation
 Arena Business Centre
 Holy Rood Close
 Poole, Dorset BH17 7FJ UK
 Tel.: +44 (0)1202 606300
 Fax: +44 (0)1202 606301
 E-Mail:
sales.automation@parker.com
<mailto:sales.automation@parker.com>
 Internet:
www.parker-automation.com
<http://www.parker-automation.com>

USA:

Parker Hannifin Corporation
 Electromechanical Automation
 5500 Business Park Drive
 Rohnert Park, CA 94928
 Phone #: (800) 358-9068
 FAX #: (707) 584-3715
 E-Mail:
CMR_help@parker.com
mailto:emn_support@parker.com
 Internet:
www.compumotor.com
<http://www.compumotor.com>

Worldwide sales

http://apps.parker.com/divapps/eme/EME/Contact_sites/Sales%20Channel_Parker-EME.pdf

Our product on the Internet: <http://www.parker-eme.com/c3>

1. Notes on the Documents Supplied

**Compax3 –
Installation manual** The present manual contains the installation instructions for the associated Compax3 device series (refer to Chapter "Device Assignment").

This installation manual does contain only the basic information; for more detailed information please refer to the Help-files of the individual Compax3 device types.

Compax3 - DVD

C3 ServoManager The enclosed self-starting* DVD contains the "C3 ServoManager" software tool for configuring, optimizing etc. Compax3.
Please use always the latest C3 ServoManager version,

Parker Integrated Engineering Tool Furthermore, the "Parker Integrated Engineering Tool", a software tool for the project management of several Parker Motion Control products, can be found on the C3 DVD.
Several axes are managed in a common project. The Compax3 ServoManager is integrated per "Plug & Play" for each Compax3 axis. The configuration, optimization,.. take place in the same way as in an independently working C3 ServoManager.

The "C3 ServoManager" software tool is also functioning independently from the Parker Integrated Engineering Tool!

Online help system After the installation of the ServoManager you can copy the desired Online help system with the "C3 ServoManager Help Installer" (you can select the C3 device type as well as the desired language) to your PC. The help system can be called up directly from the ServoManager. You will find the complete description of the selected device type in these online help files.
Please note that the help files are associated with defined device and software versions.

Catalogs The catalogs supplied provide an overview of and information on the Compax3 device series.

Adobe Acrobat Reader® For reading PDF files you need the "Adobe Acrobat Reader", a software tool which is available free of charge. and it is distributed and generally accepted throughout the world. You can also download it directly from the Adobe website at: www.adobe.com/products/acrobat.

* If your PC has not been set up accordingly, start the "start.htm" file on the CD.

1.1 C3 ServoManager

Installation of the C3 ServoManager

The Compax3 ServoManager can be installed directly from the Compax3 DVD. Click on the appropriate hyperlink or start the installation program "C3Mgr_Setup_V.... .exe" and follow the instructions.

PC requirements

Recommendation:

Operating system:	MS Windows XP SP2 / MS Windows 2000 as from SP4 / (MS Vista)
Browser:	MS Internet Explorer 6.x
Processor:	Intel Pentium 4 / Intel Core 2 Duo / AMD Athlon class as from >=2GHz
RAM memory:	>= 1024MB
Hard disk:	>= 20GB available memory
Drive:	DVD drive
Monitor:	Resolution 1024x768 or higher
Graphics card:	on onboard graphics (for performance reasons)
Interface:	USB

Minimum requirements:

Operating system:	MS Windows XP SP2 / MS Windows 2000 as from SP4
Browser:	MS Internet Explorer 6.x
Processor:	>= 1.5GHz
RAM memory:	512MB
Hard disk:	10GB available memory
Drive:	DVD drive
Monitor:	Resolution 1024x768 or higher
Graphics card:	on onboard graphics (for performance reasons)
Interface:	USB

Note:

- ◆ For the installation of the software you need administrator authorization on the target computer.
- ◆ Several applications running parallelly, reduce the performance and operability.
- ◆ especially customer applications, exchanging standard system components (drivers) in order to improve their own performance, may have a strong influence on the communication performance or even render normal use impossible.
- ◆ Operation under virtual machines such as Vware Workstation 6/ MS Virtual PC is not possible.
- ◆ Onboard graphics card solutions reduce the system performance by up to 20% and cannot be recommended.
- ◆ Operation with notebooks in current-saving mode may lead, in individual cases, to communication problems.

- Connection between PC and Compax3MP** Your PC is connected to the Compax3MP connector X3 (mains module) via an USB cable (SSK33/03).
Start the Compax3 ServoManager and make the setting for the assigned interface in the "**Options Communication settings RS232/RS485...**" menu.
The interface is marked as "USB Serial Port (COMx)" in the windows device manager. The no. of the COM port "x" may vary. You can find it in the PC under system control, system, hardware, device manager, connections.
- Device Selection** In the menu tree under device selection you can read the device type of the connected device (Online Device Identification) or select a device type (Device Selection Wizard).
- Configuration** Then you can double click on "Configuration" to start the configuration wizard. The wizard will lead you through all input windows of the configuration.

Contents

1. Notes on the Documents Supplied	3
1.1 C3 ServoManager	4
2. Introduction	7
2.1 Device assignment	7
2.2 Type specification plate	8
2.3 Packaging, transport, storage	10
2.4 Safety Instructions	11
2.4.1. General hazards	11
2.4.2. Safety-conscious working	11
2.4.3. Special safety instructions	11
2.5 Warranty conditions	13
2.6 Conditions of utilization	14
2.6.1. Conditions of utilization for CE-conform operation	14
2.6.2. Conditions of utilization for UL certification Compax3M	16
2.6.3. Current on the mains PE (leakage current)	17
2.6.4. Supply networks	18
2.7 Manufacturer's Declaration of Conformity	19
3. Device description	20
3.1 Installation instructions Compax3M	20
3.2 Mounting and dimensions	22
3.2.1. Mounting and dimensions Compax3MP10/M050-150	22
3.2.2. Installation and dimensions Compax3MP20/M300	23
3.2.3. With upper mounting, the housing design may be different	24
3.3 State of delivery	24
3.4 Meaning of the status LED - Compax3 axis controller	24
3.5 Meaning of the status LED - Compax3MP (mains module)	25
3.6 Compax3MP/Compax3M connections	26
3.6.1. Front connector	26
3.6.2. Connections on the device bottom	27
3.6.3. Connections of the axis combination	28
3.6.4. Connector and pin assignment	29
3.6.5. Control voltage 24VDC Compax3MP (mains module)	31
3.6.6. Mains supply Compax3MP (mains module)	31
3.6.7. Braking resistor / temperature switch Compax3MP (mains module)	33
3.6.8. Motor / motor brake Compax3M (axis controller)	34
3.6.9. Safety technology option for Compax3M (axis controller)	36
3.7 Communication interfaces	37
3.7.1. Communication Compax3M	37
3.8 Signal interfaces	39
3.8.1. Resolver / feedback (connector X13)	39
3.8.2. Analog / Encoder (plug X11)	40
3.8.3. Digital inputs/outputs (plug X12)	41
4. Technical data	42
5. Index	48

2. Introduction

In this chapter you can read about:

Device assignment	7
Type specification plate	8
Packaging, transport, storage	10
Safety Instructions	11
Warranty conditions	13
Conditions of utilization	14
Manufacturer's Declaration of Conformity	19

2.1 Device assignment

This manual is valid for the following devices:





- ◆ Compax3M050D6 + supplement
- ◆ Compax3M100D6 + supplement
- ◆ Compax3M150D6 + supplement
- ◆ Compax3M300D6 + supplement

- ◆ Compax3MP10D6 (mains module)
- ◆ Compax3MP20D6 (mains module)

2.2 Type specification plate

Compax3 - Type
specification plate
(Example):





The valid device version is defined by the type specification plate (on the housing):

 10	Parker Hannifin GmbH & Co. KG EME Robert-Bosch-Straße 22 77656 Offenburg Tel. +49 (0) 7844 509-0 www.parker-eme.com	
	1 2 5 6 9 8 PN: C3M050D6 F10I11T40M00S01	7 17.06.2008 Tested:
 11	3 SN: 1234567890	
 12	Power Input: 565VDC 4	
	Power Output *: 3AC 400V (0...500 Hz), 5A * see manual for further ratings (192-120148) IP20	

Explanation:

1	Type designation The complete order designation of the device (2, 5, 6, 9, 8).
2	C3: Abbreviation for Compax3 S025: Single axis device, nominal device current in 100mA (025=2.5A) M050: Multi-axis device, nominal device current in 100mA (050=5A) H050: High power device, nominal device current in 1A (050=50A) D6: Designation nominal supply V2: Mains supply voltage (2=230VAC/240VAC, 4=400VAC/480VAC)
3	Unique number of the particular device
4	Nominal supply voltage Power Input: Input supply data Power Output: Output data
5	Designation of the feedback system F10: Resolver Feedback F11: SinCos® / Single- or Multiturn F12: Feedback module for direct drives
6	Device interface I10: Analog, step/direction and encoder input I11 / I12: Digital Inputs / Outputs and RS232 / RS485 I20: Profibus DP / I21: CANopen / I22: DeviceNet / I30: Ethernet Powerlink / I31: EtherCAT C10: integrated controller C3 <i>powerPLmC</i> C13: integrated controller C3 <i>powerPLmC</i> with Profibus
7	Date of factory test
8	Options Mxx: I/O extension, HEDA Sx: optional safety technology on the C3M
9	Technology function T10: Servo controller T11: Positioning T30: Motion control programmable according to IEC61131-3 T40: Electronic cam
10	CE compliance
11	Certified safety technology (corresponding to the Logo displayed)
12	UL certification (corresponding to the Logo displayed)

Type specification plate: Compax3MP
(Example):

 8	Parker Hannifin GmbH & Co. KG EME Robert-Bosch-Straße 22 77656 Offenburg Tel. +49 (0) 781/509-0 www.parker-eme.com		
	1 2 3 4 PN: C3MP10D6USBM00		
 9	5 SN: 8887775555		Tested: 6 17.06.2008 
	7 Power Input *: 3AC 400V (50/60 Hz) , 22A		
	7 Power Output *: 565VDC, 10kW * see manual for further ratings (192-120148) IP20		

Explanation:

1	Type designation The complete order designation of the device (2 - 4).
2	C3: Abbreviation for Compax3 MPx0: Mains module 3AC 230...480V, nominal power in 1kW (10=10kW) D6: Designation nominal supply
3	Configuration and parameterization interface USB: USB connection
4	Options Mxx: I/O extension
5	Unique number of the particular device
6	Date of factory test
7	Nominal supply voltage Power Input: Input supply data Power Output: Output data
8	CE compliance
9	UL certification (corresponding to the Logo displayed)

2.3 Packaging, transport, storage

Packaging material and transport



Caution!

The packaging material is inflammable, if it is disposed of improperly by burning, lethal fumes may develop.

The packaging material must be kept and reused in the case of a return shipment. Improper or faulty packaging may lead to transport damages.

Make sure to transport the drive always in a safe manner and with the aid of suitable lifting equipment (**weight** (see page 42)). Do never use the electric connections for lifting. Before the transport, a clean, level surface should be prepared to place the device on. The electric connections may not be damaged when placing the device.

First device checkup

- ◆ Check the device for signs of transport damages.
- ◆ Verify, if the indications on the **type identifications plate** (see page 8) correspond to your requirements.
- ◆ Check if the consignment is complete.

Storage

If you do not wish to mount and install the device immediately, make sure to store it in a dry and clean environment. Make sure that the device is not stored near strong heat sources and that no metal chippings can get into the device.

Disposal

This product contains materials that fall under the special disposal regulation from 1996, which corresponds to the EC directory 91/689/EEC for dangerous disposal material. We recommend to dispose of the respective materials in accordance with the respectively valid environmental laws. The following table states the materials suitable for recycling and the materials which have to be disposed of separately.

Material Option	suitable for recycling	Disposal
Metal	yes	no
Plastic materials	yes	no
Circuit boards	no	yes

Please dispose of the circuit boards according to one of the following methods:

- ◆ Burning at high temperatures (at least 1200°C) in an incineration plant licensed in accordance part A or B of the environmental protection act.
- ◆ Disposal via a technical waste dump which is allowed to take on electrolytic aluminium condensers. Do under no circumstances dump the circuit boards at a place near a normal waste dump.

2.4 Safety Instructions

In this chapter you can read about:

General hazards	11
Safety-conscious working	11
Special safety instructions	11

2.4.1. General hazards

General Hazards on Non-Compliance with the Safety Instructions

The device described in this manual is designed in accordance with the latest technology and is safe in operation. Nevertheless, the device can entail certain hazards if used improperly or for purposes other than those explicitly intended.

Electronic, moving and rotating components can

- ◆ constitute a hazard for body and life of the user, and
- ◆ cause material damage

Designated use

The device is designed for operation in electric power drive systems (VDE0160). Motion sequences can be automated with this device. Several motion sequences can be combined by interconnecting several of these devices. Mutual interlocking functions must be incorporated for this purpose.

2.4.2. Safety-conscious working

This device may be operated only by qualified personnel.

Qualified personnel in the sense of these operating instructions consists of:

- ◆ Persons who, by virtue to their training, experience and instruction, and their knowledge of pertinent norms, specifications, accident prevention regulations and operational relationships, have been authorized by the officer responsible for the safety of the system to perform the required task and in the process are capable of recognizing potential hazards and avoiding them (definition of technical personnel according to VDE105 or IEC364),
- ◆ Persons who have a knowledge of first-aid techniques and the local emergency rescue services.
- ◆ Persons who have read and will observe the safety instructions.
- ◆ Those who have read and observe the manual or help (or the sections pertinent to the work to be carried out).

This applies to all work relating to setting up, commissioning, configuring, programming, modifying the conditions of utilization and operating modes, and to maintenance work.

This manual and the help information must be available close to the device during the performance of all tasks.

2.4.3. Special safety instructions

- ◆ Check the correct association of the device and its documentation.
- ◆ Never detach electrical connections while voltage is applied to them.
- ◆ Safety devices must be provided to prevent human contact with moving or rotating parts.
- ◆ Make sure that the device is operated only when it is in perfect condition.
- ◆ Implement and activate the stipulated safety functions and devices.
- ◆ Operate the device only with the housing closed.

- ◆ Make sure that all axes are sufficiently fixed.
- ◆ Attention during configuration downloads with master - slave couplings (electronic gear, cam)
Deactivate the drive before starting the configuration download: Master and Slave axis.
- ◆ Check that all live terminals are secured against contact. Fatal voltage levels of to 850V occur.
- ◆ Do not bypass power direct current

**Warning!**

Due to movable machine parts and high voltages, the device can pose a lethal danger. Danger of electric shock in the case of non-respect of the following instructions. The device corresponds to DIN EN 61800-3, i.e. it is subject to limited sale. The device can emit disturbances in certain local environments. In this case, the user is liable to take suitable measures.

- ◆ The device must be permanently grounded due to high earth leakage currents.
- ◆ The drive motor must be grounded with a suitable protective lead.
- ◆ The devices are equipped with high voltage DC condensers. Before removing the protective cover, the discharging time must be awaited. After switching off the energy, it may take up to 5 minutes to discharge the capacitors. Danger of electric shock in case of non respect.
- ◆ Before you can work on the device, the supply voltage must be switched off at the L1, L2 and L3 clamps. Wait at least 3 minutes so that the power direct current may sink to a secure value (<50V). Check with the aid of a voltmeter, if the voltage at the DC+ and DC- clamps has fallen to a value below 50V (not possible on the Compax3M).
- ◆ Do never perform resistance tests with elevated voltages (over 690V) on the wiring without separating the circuit to be tested from the drive.
- ◆ In the event of a device exchange it is absolutely necessary to transfer the configuration determining the correct operation of the drive to the device, before the device is put into operation.
- ◆ The device contains electrostatically sensitive components. Please heed the electrostatic protection measures while working at/with the device as well as during installation and maintenance.

**Attention - hot surface!**

The heat dissipator can reach very high temperatures (>70°C)

Protective covers**Caution!**

The user is responsible for protective covers and/or additional safety measures in order to prevent damages to persons and electric accidents.

2.5 Warranty conditions

- ◆ The device must not be opened.
- ◆ Do not make any modifications to the device, except for those described in the manual.
- ◆ Make connections to the inputs, outputs and interfaces only in the manner described in the manual.
- ◆ Fix the devices according to the mounting instructions.
We cannot provide any guarantee for any other mounting methods.

Note on exchange of options

Compax3 options must be exchanged in the factory to ensure hardware and software compatibility.

- ◆ When installing the device, make sure the heat dissipators of the device receive sufficient air and respect the recommended mounting distances of the devices with integrated ventilator fans in order to ensure free circulation of the cooling air.
- ◆ Make sure that the mounting plate is not exposed to external temperature influences.

2.6 Conditions of utilization

In this chapter you can read about:

Conditions of utilization for CE-conform operation	14
Conditions of utilization for UL certification Compax3M	16
Current on the mains PE (leakage current)	17
Supply networks	18

2.6.1. Conditions of utilization for CE-conform operation

- Industry and trade -

The EC guidelines for electromagnetic compatibility 2006/95/EC and for electrical operating devices for utilization within certain voltage limits 2004/108/EC are fulfilled when the following boundary conditions are observed:

Operation of the devices only in the condition in which they were delivered, i.e. with all housing panels.

In order to ensure contact protection, all mating plugs must be present on the device connections even if they are not wired.

Mains filter: A mains filter is required in the mains input line if the motor cable exceeds a certain length. Filtering can be provided centrally at the plant mains input or separately at the mains input to each axis combination.

Use of the devices in the industrial area (limit values class C3 in accordance with EN 61800-3)

The following mains filters are available for independent utilization:

Device: Compax3	Order No.:	Condition:
MP10	NFI03/01	Reference axis combination 6x10m
MP10	NFI03/02	Reference axis combination 6x50m
MP20	NFI03/03	Reference axis combination 6x50m

Connection length: Connection between mains filter and device:

unshielded: < 0.5m
shielded < 5m (fully shielded on ground – e.g. ground of control cabinet)

Motor and Feedback cable:

Operation of the devices only with motor and feedback cables whose plugs contain a special full surface area screening.

Requirements for Compax3M motor cable

<80m per axis (the cable must not be rolled up!)
The entire length of the motor cable per axis combination may not exceed 300m.
A motor output filter is required for motor cables >20m.

- ◆ MDR01/04 (max. 6.3A rated motor current)
- ◆ MDR01/01 (max. 16A rated motor current)
- ◆ MDR01/02 (max. 30A rated motor current)

Shielding connection of the motor cable

The cable should be fully screened and connected to the Compax3 housing. We offer a special Shield connecting terminal as accessory item (ZBH./...). The shield of the cable must also be connected with the motor housing. The fixing (via plug or screw in the terminal box) depends on the motor type.

Requirements for Compax3M encoder cable:

< 80m

Requirements for other cables

Corresponding to the specifications of the terminal clamp with a temperature range of up to 60°C.

Motors: Operation with standard motors.

Control: Use only with aligned controller (to avoid control loop oscillation).

Grounding: Connect the filter housing and the Compax3 to the cabinet frame, making sure that the contact area is adequate and that the connection has low resistance and low inductance.
Never mount the filter housing and the device on paint-coated surfaces!

Cable installation: Signal lines and power lines should be installed as far apart as possible. Signal leads should never pass close to excessive sources of interference (motors, transformers, contactors etc.).

Accessories: Make sure to use only the accessories recommended by Parker
Connect all cable shields at both ends, ensuring large contact areas!

Warning:

This is a product in the restricted sales distribution class according to EN 61800-3. In a domestic area this product can cause radio frequency disturbance, in which case the user may be required to implement appropriate remedial measures.

2.6.2. Conditions of utilization for UL certification Compax3M

UL certification for Compax3M

conform to UL:	◆ according to UL508C
Certified	◆ E-File_No.: E235 342

The UL certification is documented by a "UL" logo on the device (type specification plate).



Conditions of utilization

- ◆ The devices are only to be installed in a degree of contamination 2 environment (maximum).
- ◆ The devices must be appropriately protected (e.g. by a switching cabinet).
- ◆ Tightening torque of the field wiring terminals (green Phoenix plugs)

Device	X40: Braking Resistor	X41: Mains connector	X9: 24VDC
C3MP10	0.5 (4.43Lb.in)	1.2Nm (10.62Lb.in)	1.2Nm (10.62Lb.in)
C3MP20	0.5 (4.43Lb.in)	1.7Nm (15Lb.in)	1.2Nm (10.62Lb.in)

Device	X43: Motor connector	X15: Temperature monitoring
C3M050-150	0.5 (4.43Lb.in)	0.22Nm (1.95Lb.in)
C3M300	1.2Nm (10.62Lb.in)	0.22Nm (1.95Lb.in)

- ◆ Temperature rating of field installed conductors shall be at least 60°C Use copper lines only. Please use the cables described in the accessories chapter; they do have a temperature rating of at least 60°C
- ◆ Maximum Surrounding Air Temperature: 40°C.
- ◆ Suitable for use on a circuit capable of delivering not more than 5000 rms symmetrical amperes and 480 volts maximum.



Caution!

Risk of Electric Shock.
Discharge time of the bus capacitor is approx. 5 minutes.

- ◆ The drive provides internal motor overload protection.
This must be set so that 200% of the nominal motor current are not exceeded.
- ◆ Cable cross-sections
 - ◆ Mains input: corresponding to the recommended fuses.
 - ◆ Motor cable: corresponding to the nominal output currents (see on page 43)
- ◆ Maximum cross-section limited by the terminals mm² / AWG

Line cross-sections of the power connections (on the device bottoms)

Compax3 device:	Cross-section: Minimum... Maximum [mm ² with contactor sleeve]
M050, M100, M150	0,25 ... 4 (AWG: 23 ... 11)
M300	0,5 ... 6 (AWG: 20 ... 10)
MP10	Mains supply: 0,5 ... 6 (AWG: 20 ... 10) Braking resistor: 0,25 ... 4 (AWG: 23 ... 11)
MP20	Mains supply: 0,5 ... 16 (AWG: 20 ... 6) Braking resistor: 0,25 ... 4 (AWG: 23 ... 11)

2.6.3. Current on the mains PE (leakage current)

**Caution!**

This product can cause a direct current in the protective lead. If a residual current device (RCD) is used for protection in the event of direct or indirect contact, only a type B (all current sensitive) RCD is permitted on the current supply side of this product. On the other hand a different protective measure must be taken, such as for example separation from the environment by double or enforced insulation or separation from the supply network by a transformer.

Please heed the connection instructions of the RCD supplier.

Mains filters do have high leakage currents due to their internal capacity. An internal mains filter is usually integrated into the Compax3 servo controllers.

Additional leakage currents are caused by the capacities of the motor cable and of the motor windings. Due to the high clock frequency of the power output stage, the leakage currents do have high-frequency components. Please check if the FI protection switch is suitable for the individual application.

If an external mains filter is used, an additional leakage current will be produced.

The figure of the leakage current depends on the following factors:

- ◆ Length and properties of the motor cable
- ◆ Switching frequency
- ◆ Operation with or without external mains filter
- ◆ Motor cable with or without shield network
- ◆ Motor housing grounding (how and where)

Remark:

- ◆ The leakage current is important with respect to the handling and usage safety of the device.
- ◆ A pulsing leakage current occurs if the supply voltage is switched on.

Please note:

The device must be operated with effective grounding connection, which must comply with the local regulations for high leakage currents (>3.5mA).

Due to the high leakage currents it is not advisable to operate the servo controller with an earth leakage circuit breaker.

2.6.4. Supply networks

The Compax3 servo controller series is designed for fixed connection to TN networks (TN-C, TN-C-S or TN-S). Please note that the line-earth voltage may not exceed 300VAC.

- ◆ When grounding the neutral conductor, mains voltages of up to 480VAC are permitted.

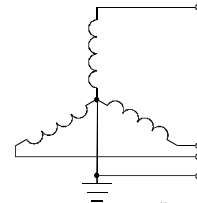

- ◆ When grounding an external conductor (delta mains, two-phase mains), mains voltages (external conductor voltages) of up to 300VAC are permitted.

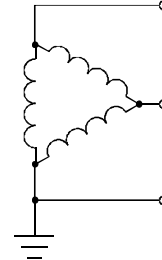

Servo controllers which are to be connected to an IT network must be provided with a separating transformer. Then the Compax3 device is operated locally like in a TN network. The secondary sided center of the separating transformer must be grounded and connected to the PE connector of the Compax3.

2.7 Manufacturer's Declaration of Conformity

As defined by the EC Electromagnetic Compatibility (EMC) Directive 2004/108/EU and

the EC Directive relating to electrical equipment designed for use within certain voltage limits (Low Voltage Directive) 2006/95/EU

We (the manufacturer)

Parker Hannifin GmbH & Co. KG

hereby declare that the designated product

Device type: Intelligent servo drives

Device models:

C3MxxxD6FxxlxxTxxMxxSxAxx

C3MPxxD6xxxMxxAxx

is, by virtue of its design concept and construction, and with reference to the version which we have put into circulation, fully compliant with the following standards or standard-related documentation.

Applied harmonized Standards, in particular:

Electromagnetic Compatibility

EN 61 800-3

EMC product standard for adjustable speed electrical power drive systems including specific test methods

Safety

EN 61 800-5-1

Safety requirements for adjustable speed electrical power drive systems

Caution!

The present Manufacturer's Declaration of Conformity is valid only if the master conditions for operation described in the "Conditions of Use" section have been met.

If there are any deviations or modifications to the product, this declaration shall cease to apply.

3. Device description

In this chapter you can read about:

Installation instructions Compax3M.....	20
Mounting and dimensions	22
State of delivery.....	24
Meaning of the status LEDs - Compax3 axis controller	24
Meaning of the status LEDs - Compax3MP (mains module)	25
Compax3MP/Compax3M connections	26
Communication interfaces	37
Signal interfaces	39

3.1 Installation instructions Compax3M

General introductory notes

- ◆ Operation of the Compax3M multi-axis combination is only possible in connection with a Compax3MP (mains module).
- ◆ Axis controllers are aligned at the right of the mains module.
- ◆ Alignment within the multi-axis combination sorted by power (with the same device types according to device utilization), the axis controller with the highest power directly at the right of the mains module.
e.g. first the device type with high utilization, at the right of this the same device type with a lower utilization.
- ◆ Max. 15 Compax3M (axis controllers) per Compax3MP (mains module) are permitted (please respect the total capacity of max. 2400µF).
- ◆ The continuation of the current rail connection outside the axis combination is not permitted and will lead to a loss of the CE and UL approbation.
- ◆ External components **may not** be connected to the rail system.

Required tools:

- ◆ Allen key M5 for fixing the devices in the control cabinet.
- ◆ Crosstip screwdriver M4 for connection rails of the DC rail modules.
- ◆ Crosstip screwdriver M5 for grounding screw of the device.
- ◆ Flat-bladed screwdriver 0.4x2.5 / 0.6x3.5 / 1.0x4.0 for wiring and mounting of the phenix clamps.

Order of installation

- ◆ Fixing the devices in the control cabinet.
 - ◆ Predrilling the mounting plate in the control cabinet according to the specifications. Dimensions (see page 22). Fit M5 screws loosely in the bores.
 - ◆ Fit device on the upper screws and place on lower screw. Tighten screws of all devices. The tightening torque depends on the screw type (e.g. 5.9Nm for M5 screw DIN 912 8.8).
- ◆ Connecting the internal supply voltages.

The Compax3M axis controllers are connected to the supply voltages via rail modules. **Details** (see page 28).

 - ◆ Deblocking the yellow protective cover with a flat-bladed screwdriver on the upper surface (click mechanism). Remove the closing devices (contact protection) that are not required from between the devices.
 - ◆ Connecting the rail modules, beginning with the mains module.

For this, loosen crosshead screws (5 screws at the right in the mains module, all 10 screws in the next axis controller), push the rails one after the other against to the left and tighten screws. Proceed accordingly for all adjacent axis controllers in the combination.

Max. tightening torque: 1.5Nm.
 - ◆ Close all protective covers. The protective covers must latch audibly.

Please Note:

Insufficiently fixed screw connections of the DC power voltage rails may lead to the destruction of the devices.

Protective covers



Caution – Risk of Electric Shock!

In order to secure the contact protection against the alive rails, it is absolutely necessary to respect the following:

- ◆ Insert the yellow plastic device at the left or right of the rails.

Make sure that the yellow plastic device is placed at the left of the first device and at the right of the last device in the combination and have not been removed.
 - ◆ Setup of the devices only with closed protective covers.
-
- ◆ Connect protective earth to mains module (M5 crossheadscrew on front of device bottom).
 - ◆ Connecting the internal communication. **Details** (see page 37).
 - ◆ Connecting the signal and fieldbus connectors. **Details** (see page 39).
 - ◆ Connection of mains power supply **Details** (see page 31) braking resistor **Details** (see page 33) and Motor **Details** (see page 34).
 - ◆ Connecting the configuration interface to the PC. **Details** (see page 37).

3.2 Mounting and dimensions

Ventilation: During operation, the device radiates heat (power loss). Please provide for a sufficient mounting distance below and above the device in order to ensure free circulation of the cooling air. Please do also respect the recommended distances of other devices. Make sure that the mounting plate is not exhibited to other temperature influences than that of the devices mounted on this very plate. The devices must be mounted vertically on a level surface. Make sure that all devices are sufficiently fixed.

3.2.1. Mounting and dimensions Compax3MP10/M050-150

Compaxa3MP and Compax3M are force-ventilated via a ventilator fan fixed to the lower part of the heat dissipator!

Mounting spacing: At the top and below: at least 100mm

Information on	C3MP (mains module) C3MP10D6	C3M (axis) C3M050D6 C3M100D6 C3M150D6
----------------	---------------------------------	--

Mounting:

2 socket head screws M5

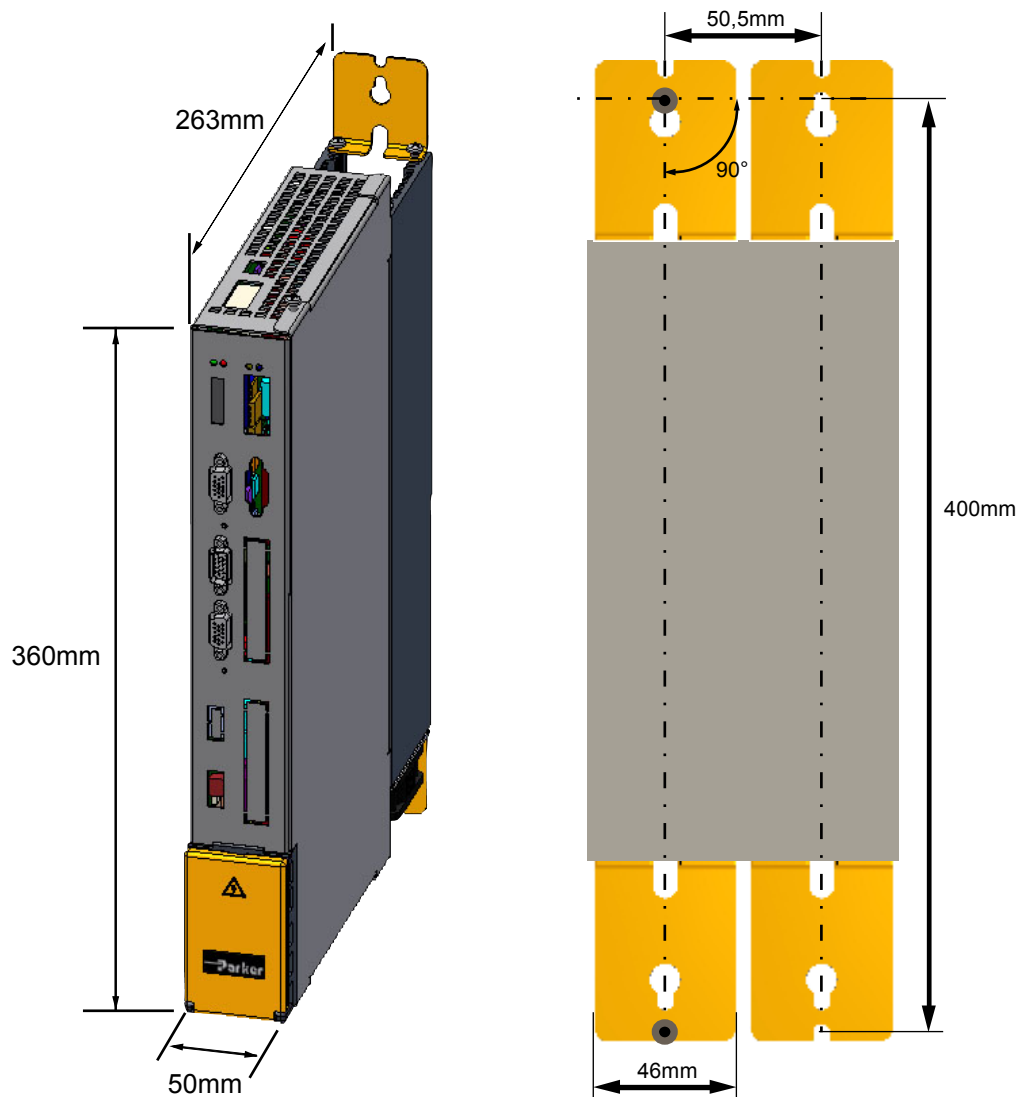

Tolerances: DIN ISO 2768-f

3.2.2. Installation and dimensions Compax3MP20/M300

Information on	C3MP (mains module) C3MP20D6	C3M (axis) C3M300D6
----------------	---------------------------------	------------------------

Mounting:

4 socket head screws M5

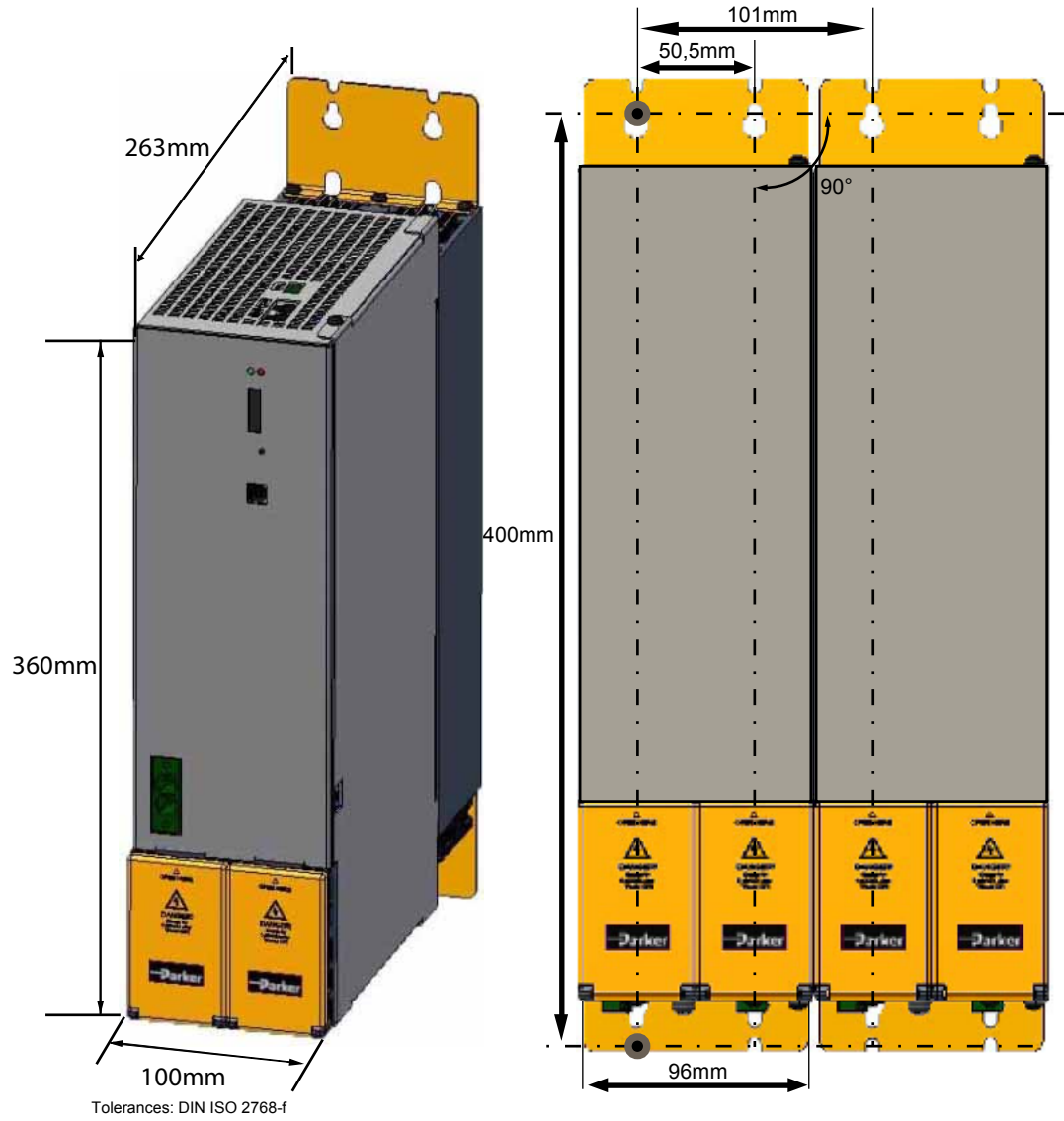

3.2.3. With upper mounting, the housing design may be different

Mounting:

3 socket head screws M5

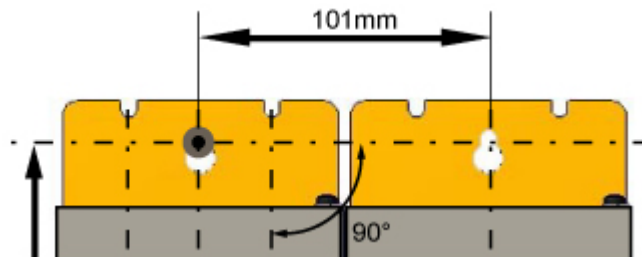

3.3 State of delivery

Compax3 is delivered without configuration!

After switching on the 25VDC supply, the red LED is flashing while the green LED is dark.

Please configure the device with the help of the Windows-Software "Compax3 – ServoManager"!

3.4 Meaning of the status LED - Compax3 axis controller

Device status LEDs	Right LED (red)	Left LED (green)
Voltages missing	off	off
During the booting sequence	alternately flashing	
No configuration present. SinCos® feedback not detected. Compax3 IEC61131-3 program not compatible with Compax3 Firmware. no Compax3 IEC61131-3 program For F12: Hall signals invalid.	Flashes slowly	off
Axis without current excitation	off	Flashes slowly
Power supplied to axis; commutation calibration running	off	Flashes quickly
Axis with current excitation	off	on
Axis in fault status / fault present / axis energized (error reaction 1)	Flashes quickly	on
Axis in fault status / fault present / axis deenergized (error reaction 2)	on	off
Compax3 faulty: Please contact us.	on	on

3.5 Meaning of the status LED - Compax3MP (mains module)

C3MP Status LEDs	Left LED (green)	Right LED (red)
Control voltage 24 VDC iss missing**	off	off
Error of mains module*	off	on
DC power voltage is built up	-	Flashes quickly
Phase failure / mains power supply undervoltage	on	Flashes slowly
Address assignment CPU active	Flashes quickly	-
Address assignment CPU completed	Flashes slowly	-
C3MPxx Ready - State	on	off
Incorrect wiring of internal communication X30/31	Flashes slowly	Flashes quickly

*can be read out in each axis controller



Caution!

When the control voltage is missing there is no indication whether or not high voltage supply is available.

3.6 Compax3MP/Compax3M connections

In this chapter you can read about:

Front connector	26
Connections on the device bottom	27
Connections of the axis combination	28
Connector and pin assignment	29
Control voltage 24VDC Compax3MP (mains module)	31
Mains supply Compax3MP (mains module)	31
Braking resistor / temperature switch Compax3MP (mains module)	33
Motor / motor brake Compax3M (axis controller)	34
Safety technology option for Compax3M (axis controller)	36

3.6.1. Front connector



MP	Power module
LED1	Status LEDs Mains module
S1	Basic address
X3	Configairiton interface (USB)
X9	Supply voltage 24VDC
M	Axis controller
LED2	Status LEDs of the axis
S10	Function
X11	Analogue/Encoder
X12	Inputs/Outputs
X13	Motor position feedback
X14	Safety technology (option)
X15	Motor temperature monitoring
LED3	HEDA LEDs
X20	HEDA in (Option)
X21	HEDA out (Option)
X22	Inputs Outputs (Option M10/12)
X23	Bus (option) connector type depends on the bus system!
X24	Bus (option) depends on the bus system!
LED4	Bus LEDs
S24	bus settings
1	Behind the yellow protective covers you can find the rails for the supply voltage connection. Supply voltage 24VDC DC power voltage supply

3.6.2. Connections on the device bottom



Caution – Risk of Electric Shock!

Always switch devices off before wiring them!
 Dangerous voltages are still present until 5 minutes after switching off the power supply.



Caution!

When the control voltage is missing there is no indication whether or not high voltage supply is available.



Attention – PE connection!

The PE connection is made with 10mm² via a grounding screw at the bottom of the device.



Attention - hot surface!

The heat dissipator can reach very high temperatures (>70°C)

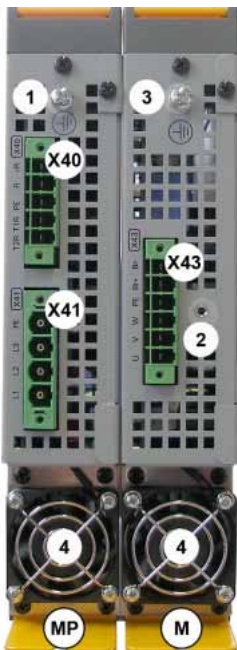

MP	Power module
X40	Braking Resistor
X41	Mains supply VAC/PE
1	Central ground connection for the axis combination, with 10mm ² to the ground screw on the housing.
4	Fan*
M	Axis controller
X43	Motor / Brake
2	Fixing for motor shield clamp
4	Fan*
3	optionally, the axis controller features a ground screw on the housing, if the grounding is not possible via the back plate.

* is internally supplied.

Line cross-sections of the power connections (on the device bottoms)

Compax3 device:	Cross-section: Minimum... Maximum [mm ² with contactor sleeve]
M050, M100, M150	0,25 ... 4 (AWG: 23 ... 11)
M300	0,5 ... 6 (AWG: 20 ... 10)
MP10	Mains supply: 0,5 ... 6 (AWG: 20 ... 10) Braking resistor: 0,25 ... 4 (AWG: 23 ... 11)
MP20	Mains supply: 0,5 ... 16 (AWG: 20 ... 6) Braking resistor: 0,25 ... 4 (AWG: 23 ... 11)

3.6.3. Connections of the axis combination

The Compax3M axis controllers are connected to the supply voltages via rails.

- ◆ Supply voltage 24VDC
- ◆ DC power voltage supply

The rails can be found behind the yellow protective covers. In order to connect the rails of the devices, you may have to remove the yellow plastic device inserted at the side.

CAUTION: Risk of Electric Shock



Caution – Risk of Electric Shock!

Please respect before opening:

- ◆ **Warning!** Risk of electric shock, disconnect Power Before Removing Cover.
- ◆ **Caution!** Risk of Electric Shock! Energy for 5 minutes after "Power Off"!



Caution – Risk of Electric Shock!

Always switch devices off before wiring them!
Dangerous voltages are still present until 5 minutes after switching off the power supply.



Caution!

When the control voltage is missing there is no indication whether or not high voltage supply is available.

Protective covers



Caution – Risk of Electric Shock!

In order to secure the contact protection against the alive rails, it is absolutely necessary to respect the following:

- ◆ Insert the yellow plastic device at the left or right of the rails.
Make sure that the yellow plastic device is placed at the left of the first device and at the right of the last device in the combination and have not been removed.
- ◆ Setup of the devices only with closed protective covers.

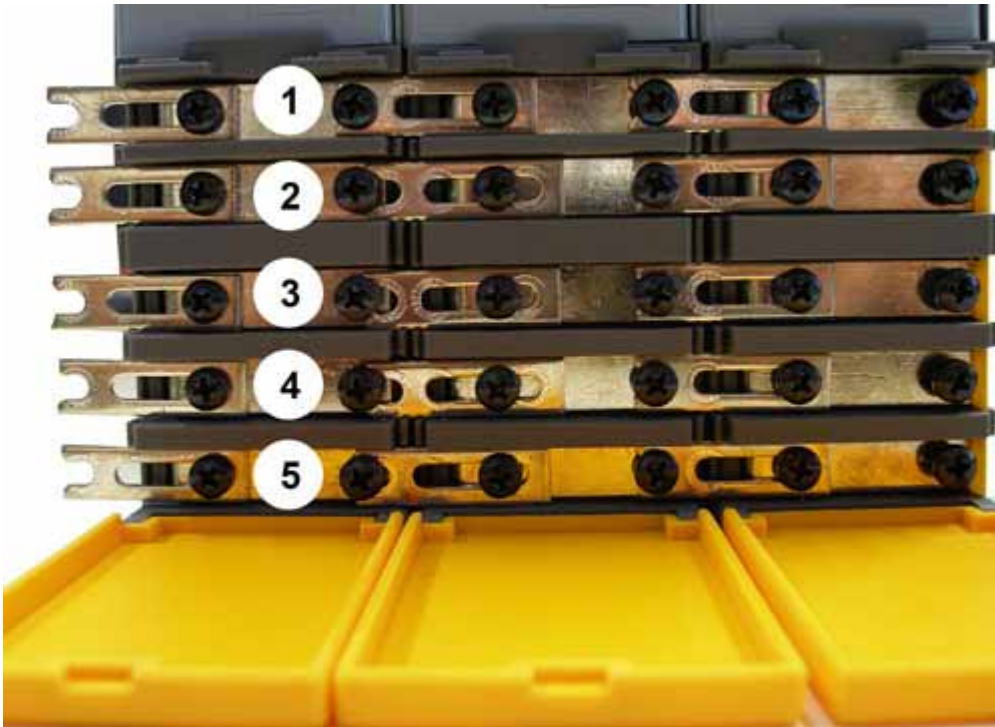

- 1 24VDC
- 2 Gnd 24 V
- 3 -HV DC
- 4 PE
- 5 +HV DC

Note: External components **may not** be connected to the rail system.

Protective covers



Caution!

The user is responsible for protective covers and/or additional safety measures in order to prevent damages to persons and electric accidents.

3.6.4. Connector and pin assignment

Overview:

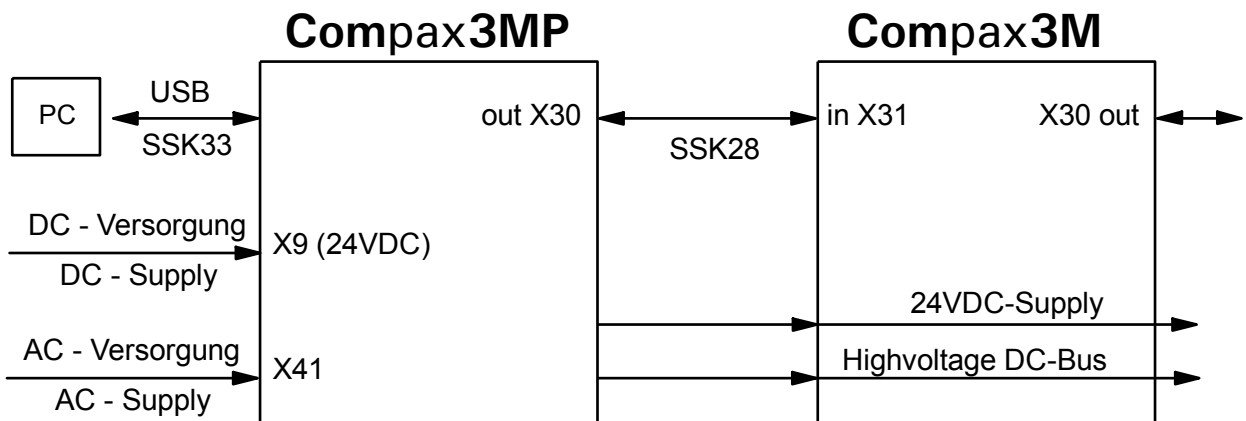

Maximum no. of C3M axes in a combination: 15 axes (max. 2400µF).

Further information on the assignment of the plug mounted at the particular device can be found below!

In detail: The fitting of the different plugs depends on the extension level of Compax3. In part, the assignment depends on the Compax3 option implemented.

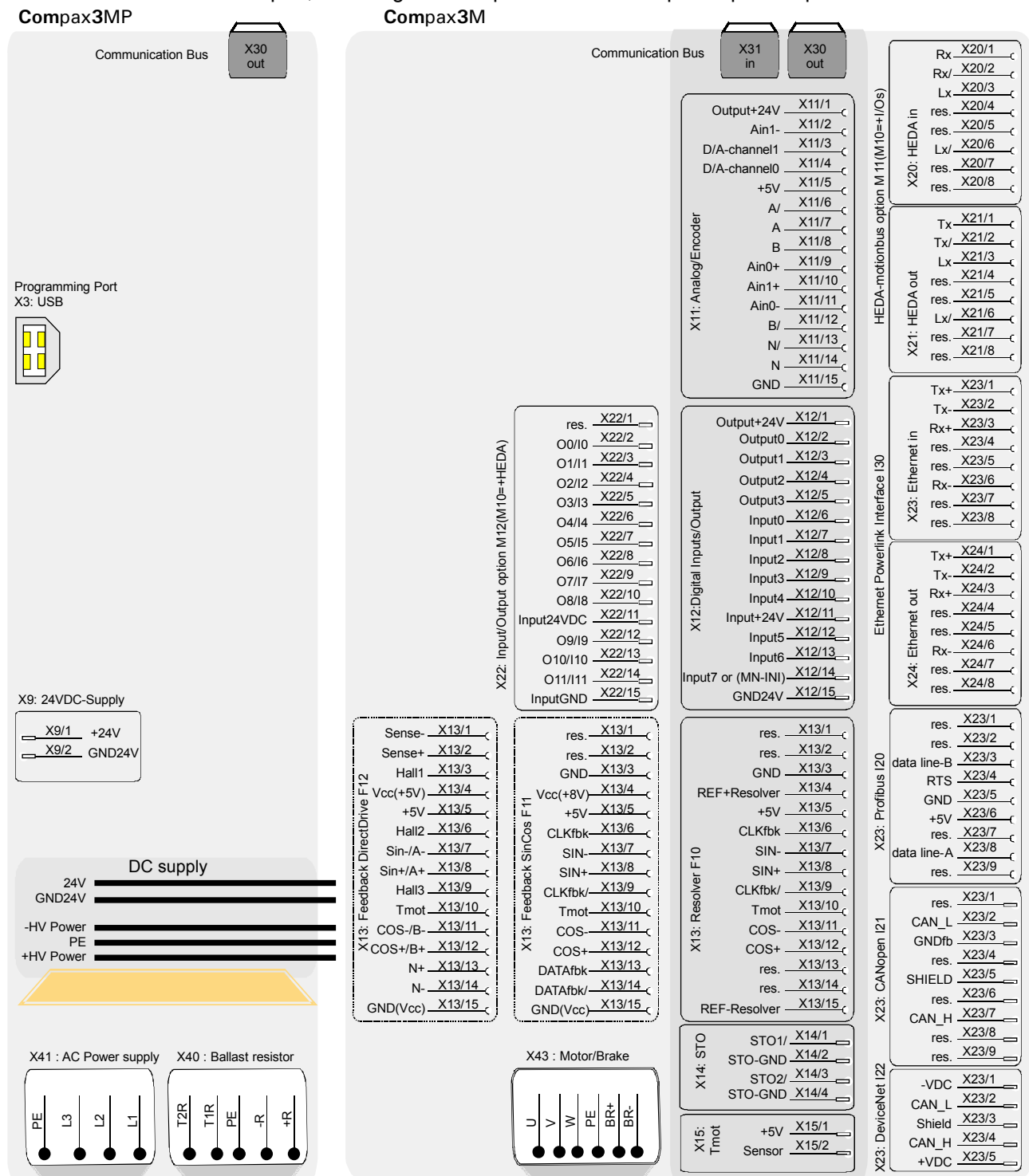

Protective covers



Caution!

The user is responsible for protective covers and/or additional safety measures in order to prevent damages to persons and electric accidents.

3.6.5. Control voltage 24VDC Compax3MP (mains module)

connector X9



PIN	Designation
1	+24V
2	Gnd 24 V

Line cross sections:
 minimum: 0.5mm² with contactor sleeve
 maximum: 6mm² with contactor sleeve
 (AWG: 20 ... 10)

Control voltage 24VDC Compax3MP / Compax3M

Device type	Compax3MP / Compax3M
Voltage range	21 - 27VDC
Mains module	with switch-on current limitation, due to capacitive load
Fuse	MCB miniature circuit breaker or "delayed action fuse", due to capacitive load
Current drain of the device	C3MP10D6: 0,2A C3MP20D6: 0.3A
Total current drain	C3M050D6: 0,85A C3M100D6: 0.85A C3M150D6: 0.85A C3M300D6: 1.0 A + Total load of the digital outputs + current for the motor holding brake
Ripple	0.5Vpp
Requirement according to safe extra low voltage (SELV)	yes
Short-circuit proof	conditional (each device internally protected with 3.15AT)

3.6.6. Mains supply Compax3MP (mains module)

Device protection

By cyclically switching on and off the power voltage, the input current limitation can be overloaded, which may cause damage to the device.

Wait at least one minute between two switching on processes!

Connector X41



PIN	Designation
	PE
	L3
	L2
	L1

Mains connection Compax3MP10D6

Device type Compax3MP10	230V	400V	480V
Supply voltage	230VAC ±10% 50-60Hz	400VAC ±10% 50-60Hz	480VAC ±10% 50-60Hz
Rated voltage	3AC 230V	3AC 400V	3AC 480V
Input current	22Aeff	22Aeff	18Arms
Output voltage	325VDC ±10%	565VDC ±10%	680VDC ±10%
Output power	6kW	10 kW	10 kW
Maximum fuse rating per device (=short circuit rating)	Measure for line and device protection: MCB miniature circuit breaker 25A according to UL category DIVQ Recommendation: (ABB) S203UP-K 25(480VAC)		

Mains connection Compax3MP20D6

Device type Compax3MP20	230V	400V	480V
Supply voltage	230VAC ±10% 50-60Hz	400VAC ±10% 50-60Hz	480VAC ±10% 50-60Hz
Rated voltage	3AC 230V	3AC 400V	3AC 480V
Input current	44Arms	44Arms	35Arms
Output voltage	325VDC ±10%	565VDC ±10%	680VDC ±10%
Output power	12kW	20kW	20kW
Maximum fuse rating per device (=short circuit rating) 2 circuit breakers in line are required	Measure for line protection: MCB with a rating of 50A / 4xxVAC (depending on the input voltage)Recommendation: Recommendation: (ABB) S203U-K50 (440VAC) Measure for device protection: Fuses 80A / 660VAC per supply leg according to UL category JFHR2 Bussmann 170M1366, 170M1566D		

Caution!

The Compax3MPxxD6 devices must only be operated with three phases!

**Caution – Risk of Electric Shock!**

Always switch devices off before wiring them!
Dangerous voltages are still present until 5 minutes after switching off the power supply.

3.6.7. Braking resistor / temperature switch Compax3MP (mains module)

The energy generated during braking operation must be dissipated via a braking resistor.

Connector X40



PIN	Description	
+R	+ Braking resistor	no short-circuit protection!
-R	- Braking resistor	
PE	PE	
T1R	Temperature Switch	
T2R	Temperature Switch	

Braking operation Compax3MPxxD6 (mains module)

Device type Compax3	MP10	MP20
Capacitance / storable energy	550µF/ 92Ws at 400V 53Ws at 480V	1175µF/ 197Ws at 400V 114Ws at 480V
Minimum braking- resistance	27Ω	15Ω
Recommended nominal power rating	500 ... 1500W	500 ... 3500W
Pulse power rating for 1s	22kW	40kW
Maximum permissible peak current	13A	15A

Braking operation Compax3MxxxD6 (axis controller)

Device type Compax3	M050	M100	M150	M300
Capacitance / storable energy	110µF/ 18Ws at 400V 10Ws at 480V	220µF/ 37Ws at 400V 21Ws at 480V	220µF/ 37Ws at 400V 21Ws at 480V	440µF/ 74Ws at 400V 42Ws at 480V

Maximum capacity in the axis combination: 2400µF

Connection of a braking resistor on Compax3MP (mains module)

Mimimum line cross section:	1.5mm ²
Maximum line length:	2m
Maximum intermediate circuit voltage:	810VDC
Switch-on threshold:	780VDC

3.6.7.1 Temperature switch Compax3MP (mains module)

Connector X40 Pin T1R, T2R

Temperature monitoring:

The temperature switch (normally closed contact) must be connected, unless an error message will be issued.

Temperature switch/relay

No galvanic separation, the temperature sensor (normally closed contact) must comply with the safe separation according to EN 60664.
 If there is no temperature monitoring due to the connected braking resistor, the T1R and T2R connections must be connected by a jumper.



Caution!

Without temperature monitoring, the braking resistor might be destroyed.

3.6.8. Motor / motor brake Compax3M (axis controller)

Connector X43



PIN	Designation
BR+	Motor holding brake *
BR-	Motor holding brake *
PE	PE (motor)
W	W (motor)
V	V (motor)
U	U (motor)

*** Please note that Compax3 will report error "open circuit at holding brake" (5481h / 2163d) if the current is below 150mA.**

Requirements for Compax3M motor cable

<80m per axis (the cable must not be rolled up!)
 The entire length of the motor cable per axis combination may not exceed 300m.
 A motor output filter is required for motor cables >20m.

- ◆ MDR01/04 (max. 6.3A rated motor current)
- ◆ MDR01/01 (max. 16A rated motor current)
- ◆ MDR01/02 (max. 30A rated motor current)

Shielding connection of the motor cable

The cable should be fully screened and connected to the Compax3 housing. We offer a special Shield connecting terminal as accessory item (ZBH./...). The shield of the cable must also be connected with the motor housing. The fixing (via plug or screw in the terminal box) depends on the motor type.

Motor cables can be found in the accessories chapter of the device description.

Motor holding brake output

Motor holding brake output	Compax3
Voltage range	21 – 27VDC
Maximum output current (short circuit proof)	1.6A
Minimum output current	150mA
Securing of brake Compax3M	3.15A



Attention – Wiring of the motor holding brake!

Connect the brake only on motors which have a holding brake! Otherwise make no brake connections at all.

Requirements cables for motor holding brake

If a motor holding brake is present, a cable of the motor holding brake must be fed on the device side through the toroidal core ferrite provided as accessory ZBH0x/xx (63Ω @1MHz, di=5.1mm), in order to ensure error-free switching on and off of the motor holding brake.

3.6.8.1 Measurement of the motor temperature of Compax3M (axis controller)

Connector X15

The acquisition of the motor temperature by the axis controller can either take place via the connection of X15 (Tmot) or via the feedback cable and the corresponding connection on X13 PIN10.



PIN	Description
1	+5V
2	Sensor

The temperature acquisition on X15 Tmot can not be connected at the same time as X13 Pin 10.

3.6.9. Safety technology option for Compax3M (axis controller)

Connector X14



PIN	Description	
1	STO1/	+24VDC
2	STO-GND	GND
3	STO2/	+24VDC
4	STO-GND	GND



Note!

If the Compax3M axis controller features a safety option, these connections must also be wired, unless it is not possible to set up the axis.

3.7 Communication interfaces

3.7.1. Kommunikation Compax3M

In this chapter you can read about:

PC - Compax3MP (mains module).....37
 Communication in the axis combination (connector X30, X31).....37
 Adjusting the basic address.....38
 Setting the axis function38

3.7.1.1 PC - Compax3MP (mains module)

Connector X3



USB2.0

Connect your PC to the USB sleeve X3 of the mains module via an USB cable (SSK33/03).

3.7.1.2 Communication in the axis combination (connector X30, X31)

The communication in the axis combination is implemented via a SSK28 cable and double RJ45 sleeves on the device top.

Beginning with the Compax3MP (mains module) the connection is always made from X30 to X31 of the next device. On the first device (X31) and the last device (X30) in the multi-axis combination, a bus termination plug (BUS07/01) is required.

Orientation to the back



Orientation to the front plate

Compax3MP (mains module)	
X30	out
X31	in
res.	reserved
Compax3M (axis)	
X30	out
X31	in
res.	reserved

3.7.1.3 Adjusting the basic address

On the mains module, the basic address of the device combination is set in steps of 16 with the aid of the first three dip switches.

The mains module contains the set basic address while the axes placed at the right in the combination contain the following addresses.

Switch S1



Address setting

Basic addresses

Switch	Value upon ON
1	16
2	32
3	64

Settings:

left: OFF

right: ON

Settable value range: 0, 16, 32, 48, 64, 80, 96, 112

Address of the 1st Compax3M = basic address+1

The addresses of the axis controllers are newly assigned after PowerOn.

Example:

Basic address = 48; mains module with 6 Compax3M axes in the combination.

1. Axis right: Address = 49

2. Axis right: Address = 50

...

6. Axis right: Address = 54

3.7.1.4 Setting the axis function

Switch S10



Function settings for T30 and T40

The value of switch S10 on the axis controller is stored in object O110.1

C3plus.Switch_DeviceFunction and can be evaluated with the aid of a program.

This helps realize a more simple function selection.

3.8 Signal interfaces

In this chapter you can read about:

Resolver / Feedback (connector X13)39
 Analog / Encoder (plug X11)40
 Digital inputs/outputs (plug X12).....41

3.8.1. Resolver / feedback (connector X13)



PIN X13	Feedback /X13 High Density /Sub D (depending on the Feedback module)		
	Resolver (F10)	SinCos (F11)	EnDat 2.1 (F12)
1	Reserved	Reserved	Sense -*
2	Reserved	Reserved	Sense +*
3	GND	GND	Reserved
4	REF-Resolver+	Vcc (+8V)	Vcc (+5V) * max. 350mA load
5	+5V (for temperature sensor)		
6	Reserved	Reserved	CLKfbk
7	SIN-	SIN-	SIN- / A- (Encoder)
8	SIN+	SIN+	SIN+ / A+ (Encoder)
9	Reserved	Reserved	CLKfbk/
10	Tmot*	Tmot*	Tmot*
11	COS-	COS-	COS- / B- (Encoder)
12	COS+	COS+	COS+ / B+ (Encoder)
13	Reserved	DATAfbk	DATAfbk
14	Reserved	DATAfbk/	DATAfbk/
15	REF-Resolver-	GND (Vcc)	GND (Vcc)

*X13 Pin10 Tmot may not be connected at the same time as X15 (on Compaxx3M).

Resolver cables can be found in the accessories chapter of the device description.
 SinCos® - cables can be found in the accessories chapter of the device description.
 The EnDat cable GBK38 can be found in the accessories chapter of the device description.

PIN X13	Feedback /X13 High Density /Sub D
	Direct drives (F12)
1	Sense -*
2	Sense +*
3	Hall1 (digital)
4	Vcc (+5V) * max. 350mA load
5	+5V (for temperature- and hall-sensors)
6	Hall2 (digital)
7	SIN-, A- (Encoder) or analog Hall sensor
8	SIN+, A+, (Encoder) or analog Hall sensor
9	Hall3 (digital)
10	Tmot*
11	COS-, B- (Encoder) or analog Hall sensor
12	COS+, B+ (Encoder) or analog Hall sensor
13	N+
14	N-
15	GND (Vcc)

*X13 Pin10 Tmot may not be connected at the same time as X15 (on Compaxx3M).

Note on F12:

*+5V (Pin 4) is measured and controlled directly at the end of the line via Sense – and Sense +.
 Maximum cable length: 100m

Caution!

- ◆ Pin 4 and Pin 5 must under no circumstances be connected!
- ◆ Plug in or pull out feedback connector only in switched off state (24VDC switched off).

3.8.2. Analog / Encoder (plug X11)



PIN X11	Reference High Density Sub D		
		Encoders	SSI
1	+24V (output) max. 70mA		
2	Ain1 -: analog input - (14Bit; max. +/-10V)		
3	D/A monitor channel 1 ($\pm 10V$, 8-bit resolution)		
4	D/A monitor channel 0 ($\pm 10V$, 8-bit resolution)		
5	+5V (output for encoder) max. 150mA		
6	- Input: steps RS422 (5V - level)	A/ (Input / simulation)	Clock-
7	+ Input: steps RS422 (5V - level)	A (Input / simulation)	Clock+
8	+ Input: direction RS422 (5V - level)	B (Input / simulation)	
9	Ain0 +: analog input + (14Bit; max. +/-10V)		
10	Ain1 +: analog input + (14Bit; max. +/-10V)		
11	Ain0 -: analog input - (14Bit; max. +/-10V)		
12	- Input: direction RS422 (5V - level)	B/ (Input / simulation)	
13	Reserved	N/ (Input / simulation)	DATA-
14	Reserved	N (Input / simulation)	DATA+
15	GND		

Technical data X11 (see on page 46)

3.8.2.1 Wiring of analog interfaces

Output

Input

Compax3

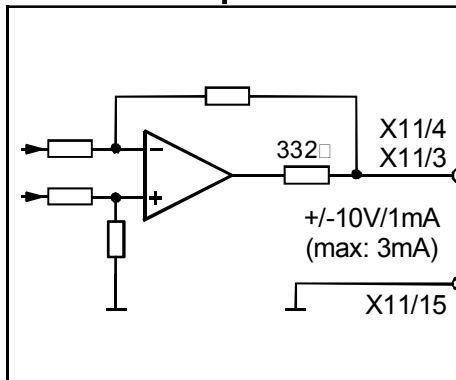

Compax3

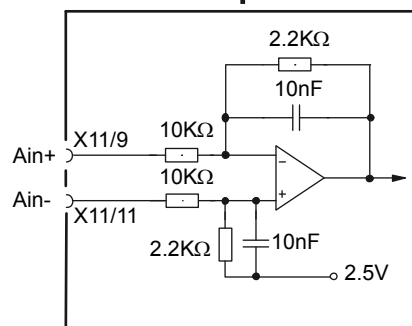

Please note: with Ain- on earth and Ain+ open, 2.02V are read in.

Structure image of the internal signal processing of the analog inputs
Ain1 (X11/10 and X11/2) has the same wiring!

3.8.2.2 Connections of the encoder interface

Compax3

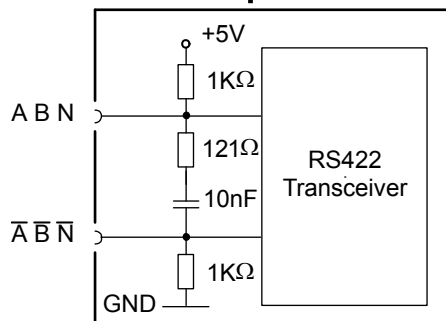

The input connection is available in triple (for A & /A, B & /B, N & /N)

3.8.3. Digital inputs/outputs (plug X12)



Pin X12	Input/output	I/O X12 High density/Sub D
1	Output	+24VDC output (max. 340mA)
2	O0	Output 0 (max. 100mA)
3	O1	Output 1 (max. 100mA)
4	O2	Output 2 (max. 100mA)
5	O3	Output 3 (max. 100mA)
6	I0	Input 0
7	I1	Input 1
8	I2	Input 2
9	I3	Input 3
10	I4	Input 4
11	I	24V input for the digital outputs Pins 2 to 5
12	I5	Input 5
13	I6	Input 6
14	I7	Input 7
15	Output	Gnd 24 V

All inputs and outputs have 24V level.

The exact assignment depends on the the device type!

You will find the description of the device-specific assignment in the online help which can be opened from the Compax3 – ServoManager.

Maximum capacitive loading of the outputs: 30nF (max. 2 Compax3 inputs).

3.8.3.1 Connection of the digital Outputs/Inputs

Wiring of digital outputs

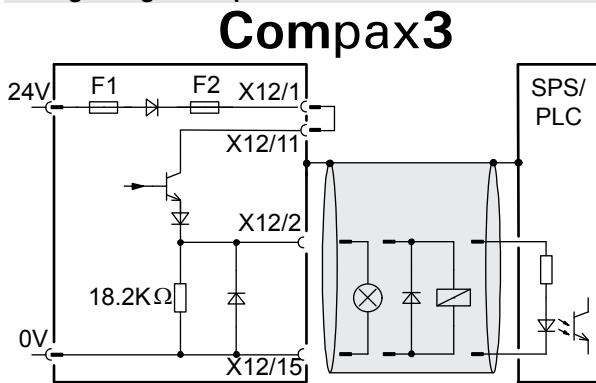

The circuit example is valid for all digital outputs!
The outputs are short circuit proof; a short circuit generates an error.

Status of digital inputs

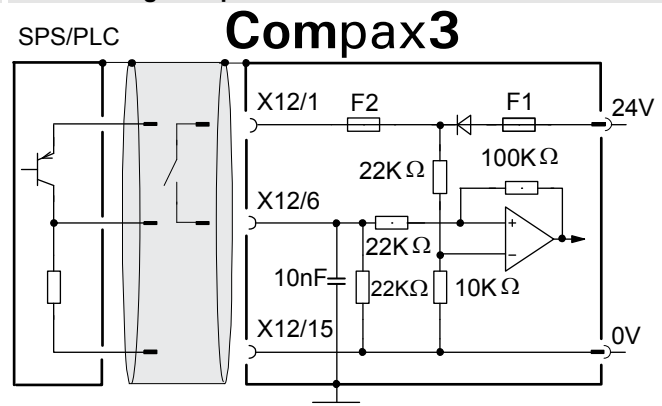

The circuit example is valid for all digital inputs!

Signal level:

◆ > 9.15V = "1" (38,2% of the control voltage applied)

◆ > 8.05V = "0" (33.5% of the control voltage applied)

F1: delayed action fuse

F2: quick action electronic fuse; can be reset by switching the 24VDC supply off and on again.

4. Technical data

Size / weight of Compax3MP/Compax3M

Device type	Dimensions HxWxD [mm]	Weight [kg]
Compax3MP10D6	360 x 50 x 263	3.95
Compax3MP20D6	360 x 100 x 263	6.3
Compax3M050D6	360 x 50 x 263	3.5
Compax3M100D6	360 x 50 x 263	3.6
Compax3M150D6	360 x 50 x 263	3.6
Compax3M300D6	360 x 100 x 263	5.25

Protection type IP20

Mains connection Compax3MP10D6

Device type Compax3MP10	230V	400V	480V
Supply voltage	230VAC ±10% 50-60Hz	400VAC ±10% 50-60Hz	480VAC ±10% 50-60Hz
Rated voltage	3AC 230V	3AC 400V	3AC 480V
Input current	22Aeff	22Aeff	18Arms
Output voltage	325VDC ±10%	565VDC ±10%	680VDC ±10%
Output power	6kW	10 kW	10 kW
Maximum fuse rating per device (=short circuit rating)	Measure for line and device protection: MCB miniature circuit breaker 25A according to UL category DIVQ Recommendation: (ABB) S203UP-K 25(480VAC)		

Mains connection Compax3MP20D6

Device type Compax3MP20	230V	400V	480V
Supply voltage	230VAC ±10% 50-60Hz	400VAC ±10% 50-60Hz	480VAC ±10% 50-60Hz
Rated voltage	3AC 230V	3AC 400V	3AC 480V
Input current	44Arms	44Arms	35Arms
Output voltage	325VDC ±10%	565VDC ±10%	680VDC ±10%
Output power	12kW	20kW	20kW
Maximum fuse rating per device (=short circuit rating) 2 circuit breakers in line are required	Measure for line protection: MCB with a rating of 50A / 4xxVAC (depending on the input voltage)Recommendation: Recommendation: (ABB) S203U-K50 (440VAC) Measure for device protection: Fuses 80A / 660VAC per supply leg according to UL category JFHR2 Busmann 170M1366, 170M1566D		

Control voltage 24VDC Compax3MP / Compax3M

Device type	Compax3MP / Compax3M
Voltage range	21 - 27VDC
Mains module	with switch-on current limitation, due to capacitive load
Fuse	MCB miniature circuit breaker or "delayed action fuse", due to capacitive load
Current drain of the device	C3MP10D6: 0,2A C3MP20D6: 0.3A
Total current drain	C3M050D6: 0,85A C3M100D6: 0.85A C3M150D6: 0.85A C3M300D6: 1.0 A + Total load of the digital outputs + current for the motor holding brake
Ripple	0.5Vpp
Requirement according to safe extra low voltage (SELV)	yes
Short-circuit proof	conditional (each device internally protected with 3.15AT)

Output data Compax3Mxxx at 3*230VAC

Device type Compax3	M050D6	M100D6	M150D6	M300D6
Power Input	325VDC \pm 10%			
Output voltage	3x 0-230V (0...500Hz)			
Nominal output current	5Aeff	10Aeff	15Aeff	30Aeff
Pulse current for 5s *	10Aeff	20Aeff	30Aeff	60Aeff
Power	2kVA	4kVA	6kVA	12kVA
Switching frequency	8kHz	8kHz	8kHz	8kHz
Power loss for In	70W ^{**}	90W ^{**}	120W ^{**}	270W ^{**}

*Turning frequency for pulse current: $f > 5\text{Hz}$

** Maximum additional losses with option card 5W.

Output data Compax3Mxxx at 3*400VAC

Device type Compax3	M050D6	M100D6	M150D6	M300D6
Power Input	565VDC \pm 10%			
Output voltage	3x 0-400V (0...500Hz)			
Nominal output current	5Aeff	10Aeff	15Aeff	30Aeff
Pulse current for 5s *	10Aeff	20Aeff	30Aeff	60Aeff
Power	3.33kVA	6.66kVA	10kVA	20kVA
Switching frequency	8kHz	8kHz	8kHz	8kHz
Power loss for In	70W ^{**}	90W ^{**}	120W ^{**}	270W ^{**}

*Turning frequency for pulse current: $f > 5\text{Hz}$

** Maximum additional losses with option card 5W.

Output data Compax3Mxxx at 3*480VAC

Device type Compax3	M050D6	M100D6	M150D6	M300D6
Power Input	680VDC ±10%			
Output voltage	3x 0-480V (0...500Hz)			
Nominal output current	4Aeff	8Arms	12.5Arms	25Arms
Pulse current for 5s *	8Arms	16Arms	25Arms	50Arms
Power	3.33kVA	6.66kVA	10kVA	20kVA
Switching frequency	8kHz	8kHz	8kHz	8kHz
Power loss for In	70W+**	90W+**	120W+**	270W+**

*Turning frequency for pulse current: f>5Hz

** Maximum additional losses with option card 5W.

Resolution of the motor position

For option F10: Resolver Feedback	<ul style="list-style-type: none"> ◆ Position resolution: 16 Bit (= 0.005°) ◆ Absolute accuracy: ±0,167°
For option F11: SinCos®	<ul style="list-style-type: none"> ◆ Position resolution: 13.5Bit/Encoder sine period => 0.03107°/encoder resolution
For option F12:	<ul style="list-style-type: none"> ◆ Maximum position resolution <ul style="list-style-type: none"> ◆ Linear: 24 Bits per motor magnet spacing ◆ Rotary: 24 bits per motor revolution ◆ For 1Vss sine-cosine encoders (e.g. EnDat): 13.5 bits / graduation of the scale of the encoder ◆ For RS 422 encoders: 4x encoder resolution ◆ Accuracy of the feedback zero pulse acquisition = accuracy of the feedback resolution ◆ Resolution for analog hall sensors with 1Vss signal: 13.5 bits / motor magnet spacing

Accuracy

The exactitude of the position signal is above all determined by the exactitude of the feedback system used.

Motors and feedback systems supported

Motors Direct drives ◆ Linear motors ◆ Torque motors	◆ Sinusoidal commutated synchronous motors <ul style="list-style-type: none"> ◆ Maximum rotating field frequency: 1,000Hz ◆ Max. velocity at 8 pole motors: 15000min⁻¹. ◆ General max. speed: 60*1000/number of pole pairs in [min⁻¹]. ◆ Max. number of poles = 600 ◆ Sinusoidal commutated asynchronous motors <ul style="list-style-type: none"> ◆ Maximum rotating field frequency: 1,000Hz ◆ Max. speed: 60*1000/number of pole pairs - slip in [min⁻¹]. ◆ Field suppression: typically up to triple (higher on request). ◆ Temperature sensor: KTY84-130 (insulated according to EN60664-1 or IEC60664-1) ◆ 3 phase synchronous direct drives
Position encoder (Feedback)	<u>Option F10: Resolver Feedback</u>
LTN:	◆ JSSBH-15-E-5 ◆ JSSBH-21-P4 ◆ RE-21-1-A05 ◆ RE-15-1-B04
Tamagawa:	◆ 2018N321 E64
Siemens:	◆ 23401-T2509-C202
	<u>Option F11: SinCos®</u>
	◆ Singleturn (SICK Stegmann) ◆ Multiturn (SICK Stegmann) Absolute position up to 4096 motor revolutions. ◆ Rotary feedback with HIPERFACE® interface: For example: SRS50, SRM50, SKS36, SKM36, SEK52

Special encoder systems for direct drives	Option F12
Analog hall sensors	<ul style="list-style-type: none"> ◆ Sine - Cosine signal (max. 5Vss*; typical 1Vss) 90° offset ◆ U-V signal (max. 5Vss*; typical 1Vss) 120° offset.
Encoder (linear or rotatory)	<ul style="list-style-type: none"> ◆ Sine-cosine (max. 5Vss*; typical 1Vss) (max. 400kHz) or ◆ TTL (RS422) (max. 5MHz) with the following modes of commutation: ◆ Automatic commutation or ◆ Digital hall sensors (e.g. DiCoder®)
Digital, bidirectional interface	<ul style="list-style-type: none"> ◆ All EnDat 2.1 or EnDat 2.2 feedback systems with incremental track (sine-cosine track) ◆ linear or rotary ◆ max. 400kHz Sine-Cosine
Distance coded feedback systems	<ul style="list-style-type: none"> ◆ Distance coding with 1VSS - Interface ◆ Distance coding with RS422 - Interface (Encoder)

*Max. differential input between SIN- (X13/7) and SIN+ (X13/8).

Motor holding brake output

Motor holding brake output	Compax3
Voltage range	21 – 27VDC
Maximum output current (short circuit proof)	1.6A
Minimum output current	150mA
Securing of brake Compax3M	3.15A

Safety technology Compax3MP / Compax3M

Safety technology as an option State-of-the-art EN ISO 13849	◆ Please respect the stated safety technology on the type designation plate (see on page 8) and the circuitry examples
--	---

UL certification for Compax3M

conform to UL:	◆ according to UL508C
Certified	◆ E-File_No.: E235 342

The UL certification is documented by a "UL" logo on the device (type specification plate).



Insulation requirements

Protection class	Protection class I according to EN 60664-1
Protection against human contact with dangerous voltages	According to
Overvoltage category	Voltage class III according to EN 60664-1
Pollution degree	Degree of contamination 2 according

Environmental conditions Compax3MP / Compax3M

General ambient conditions	In accordance with EN 60 721-3-1 to 3-3 Climate (temperature/humidity/barometric pressure): Class 3K3	
Permissible ambient temperature:		
Operation	0 to +40 °C	Class 3K3
Storage	-25 to +70 °C	
Transport	-25 to +70 °C	
Tolerated humidity:	No condensation	
Operation	<= 85% class 3K3	(Relative humidity)
Storage	<= 95%	
Transport	<= 95%	
Elevation of operating site	<=1000m above sea level for 100% load ratings <=2000m above sea level for 1% / 100m power reduction Please inquire for greater elevations	
Sealing	IP20 protection class according to EN 60 529	
Mechanic resonances:	Class 2M3, 20m/s ² ;8-200Hz	

Cooling Compax3MP / Compax3M

Cooling mode:	Forced air ventilation with fan in the heat dissipator
----------------------	--

EMC limit values Compax3MP/Compax3M

EMC interference emission	Limit values according to EN 61 800-3, Limit value class C3 with mains filter.
EMC disturbance immunity	Industrial area limit values in accordance with EN 61 800-3

EC directives and harmonised EC norms

EC low voltage directive 2006/95/EG	EN 61800-5-1 , Standard for electric power drives with settable speed; requirements to electric safety EN 60664-1 , isolation coordinates for electrical equipment in low-voltage systems EN 60 204-1, Machinery norm , partly applied
EC-EMC directive 2004/108/EG	EN 61 800-3, EMC norm Product standard for variable speed drives

Detailed information on the technical data of the Compax3 devices can be found in the Help- or PDF-files of the individual Compax3 device types.

5. Index

A

Adjusting the basic address • 38
Analog / Encoder (plug X11) • 40

B

Braking resistor / temperature switch
Compax3MP (mains module) • 33

C

C3 ServoManager • 4
Communication in the axis combination
(connector X30, X31) • 37
Communication interfaces • 37
Communication Compax3M • 37
Compax3MP/Compax3M connections • 26
Conditions of utilization • 14
Conditions of utilization for CE-conform
operation • 14
Conditions of utilization for UL certification
Compax3M • 16
Connection of the digital Outputs/Inputs • 42
Connections of the axis combination • 28
Connections of the encoder interface • 41
Connections on the device bottom • 27
Connector and pin assignment • 29
Control voltage 24VDC Compax3MP (mains
module) • 31
Current on the mains PE (leakage current) • 17

D

Designated use • 11
Device assignment • 7
Device description • 20
Digital inputs/outputs • 42
Digital inputs/outputs (plug X12) • 41

F

Front connector • 26

G

General hazards • 11

I

Installation and dimensions
Compax3MP20/M300 • 23
Installation instructions Compax3M • 20
Introduction • 7

L

LEDs • 24, 25
Level • 42

M

Mains supply Compax3MP (mains module) •
31
Manufacturer's Declaration of Conformity • 19

Meaning of the status LEDs - Compax3 axis
controller • 24

Meaning of the status LEDs - Compax3MP
(mains module) • 25

Measurement of the motor temperature of
Compax3M (axis controller) • 35

Motor / motor brake Compax3M (axis
controller) • 34

Mounting and dimensions • 22

Mounting and dimensions
Compax3MP10/M050-150 • 22

N

Notes on the Documents Supplied • 3

P

Packaging, transport, storage • 10
PC - Compax3MP (mains module) • 37
Plug assignment Compax3S0xx V2 • 39

R

Resolver / Feedback (connector X13) • 39
Resolver Feedback • 39

S

Safety Instructions • 11
Safety technology option for Compax3M (axis
controller) • 36
Safety-conscious working • 11
Setting the axis function • 38
Signal interfaces • 39
Special safety instructions • 12
State of delivery • 24
Status LEDs • 24, 25
Supply networks • 18

T

Technical data • 43
Temperature switch Compax3MP (mains
module) • 34
Type specification plate • 8

W

Warranty conditions • 13
Wiring of analog interfaces • 41
With upper mounting, the housing design may be different •
24

X

X11 • 40
X12 • 41
X13 • 39